

**Black Cat Blades Ltd.**

**JOMA 6000**



## **Installation & Use Guide**

The JOMA 6000 is a unique snow plow blade that offers exceptional characteristics for many high speed plowing operations. Proper installation and operation is critical to achieving the desired results. To maximize the benefits of using the system all first time installers and users should read this guide completely.

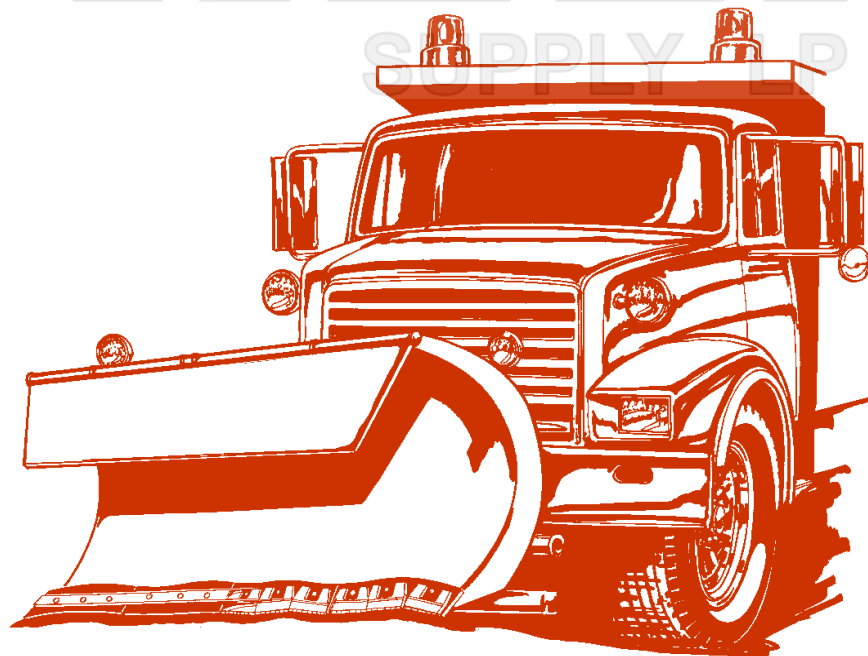

# JOMA 6000 by Black Cat Blades

## Installation Suitability

### Product Description:

The JOMA 6000 blade system is made up of independent tungsten carbide inserted segments suspended in a rubber blade. One segment is positioned per foot of finished blade. These specially shaped segments are completely surrounded by rubber and are not directly attached to the plow. The segment is allowed to float in the rubber under the weight of the plow, which allows the blade to conform to the shape of the road surface. This flexibility allows the blade to produce a cleaner surface than traditional solid plow blades while proving to be less damaging to road surfaces and markings. If installed properly the blade will reduce vibration and road chatter as well as dramatically reduce the noise level.

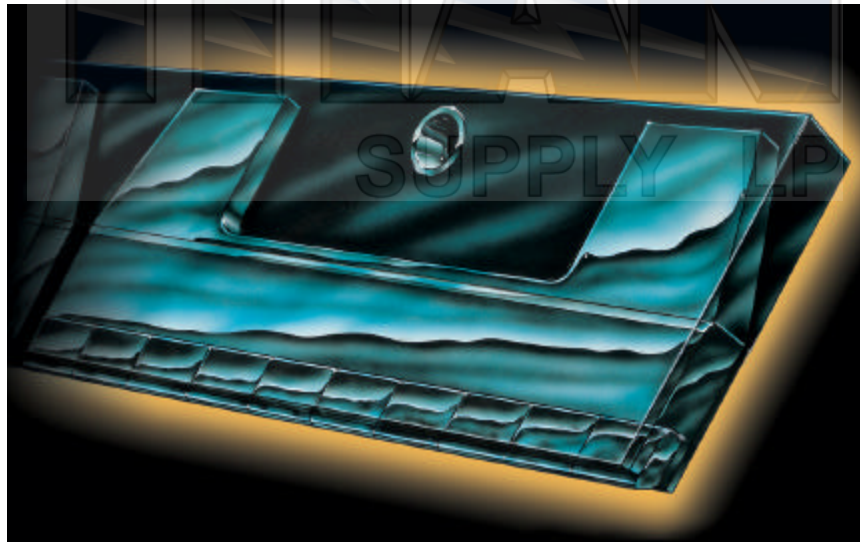

This three dimensional view of the one foot segment shows the steel inserted segment inside the rubber. The upper portions of the segment, or “ears”, are sandwiched between a clamping bar and the moldboard. This allows each segment to move independently inside the rubber blade.

# JOMA 6000 by Black Cat Blades

## Installation Suitability

### Bolt Hole Spacing:

The JOMA blade is manufactured in 12 inch increments. Each 12 inch section is held in place with one bolt in the center holding the clamping bar over the ears of the segment. For this reason, the JOMA blade must be bolted to the plow at 12 inch centers (6 inches to the first and last bolt). If the moldboard of the plow is other than 12 inch centers, an adapter blade must be used to accommodate the movement of the segments. This simple adapter will have 2 rows of holes, the top row to mount to the plow and a second row to accommodate the JOMA mounting as shown in the drawing below.

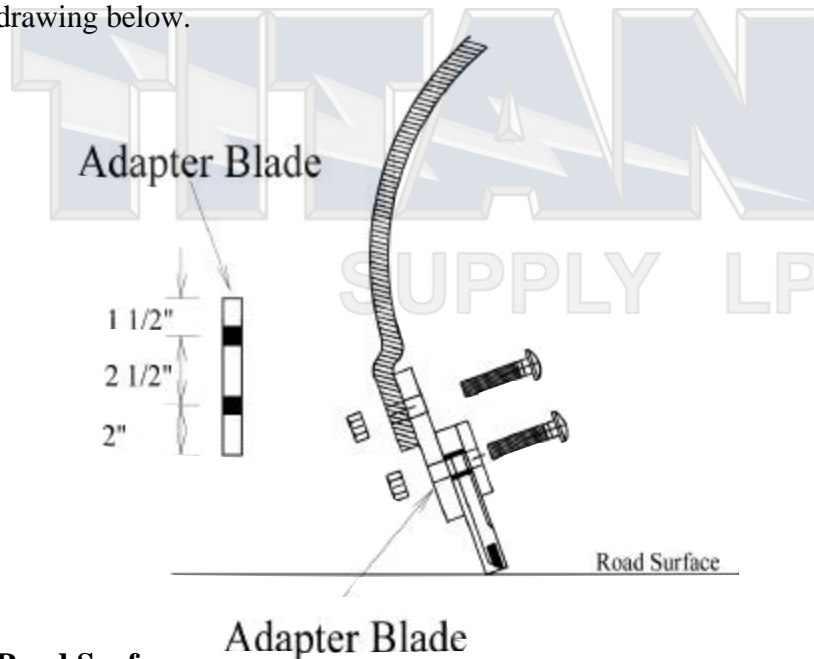

### Road Surfaces:

The JOMA system is designed for use on hard surfaces, it is recommended that the blade never be used on gravel or any other soft surface as the biting action results in damage to the segments.

# JOMA 6000 by Black Cat Blades

## Installation Suitability

### Stepped or Short Moldboard:

It is recommended the JOMA blade be used with a minimum of 2 inches of back support below the mounting holes to support the segment. If the distance from the center of the mounting holes to the bottom of the moldboard is less than 2 inches, a backing blade should be considered.

A step in the moldboard above the cutting edge does not allow the JOMA blade segment to move and “seat” as required. From the center of the mounting holes, for 2-1/2 inches up the moldboard, a smooth surface is required. If there is a step, as shown in the drawing below, a backing blade will be required that will allow the JOMA to “seat” itself up into the rubber and allow the desired movement of the segments.

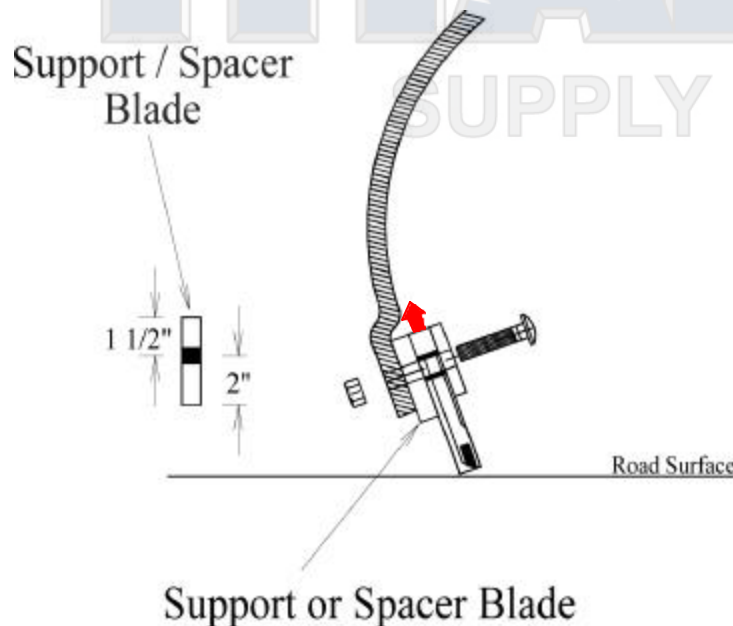

NOTE: If the installation required an adapter blade as shown on the previous page, the stepped moldboard and backing support problems have already been solved by the adapter blade. No further spacer or adapter is required.

# JOMA 6000 by Black Cat Blades

## Installation Suitability

### Moldboard (Bottom) Trip Plows:

**IMPORTANT**

The JOMA blade has an aggressive tendency to “bite” into the surface; this biting action causes weaker bottom trip mechanisms to be activated unnecessarily, which can result in damage to the JOMA system.. The JOMA system is **not recommended** for use with a bottom blade trip mechanism because the trip must be disabled to prevent excessive bounce or chatter.

### Operating Angle - Front Plows:

The recommended installation requires a moldboard angle of between 15 and 25 degrees back from zero (zero = straight up from the road surface). This approach angle allows the JOMA blade to function at it's best. Closer to straight up and down could result in chatter and bounce as the JOMA blade is trying to “bite” into the surface. Steeper angles can allow the moldboard to bottom out before the JOMA blade is worn.

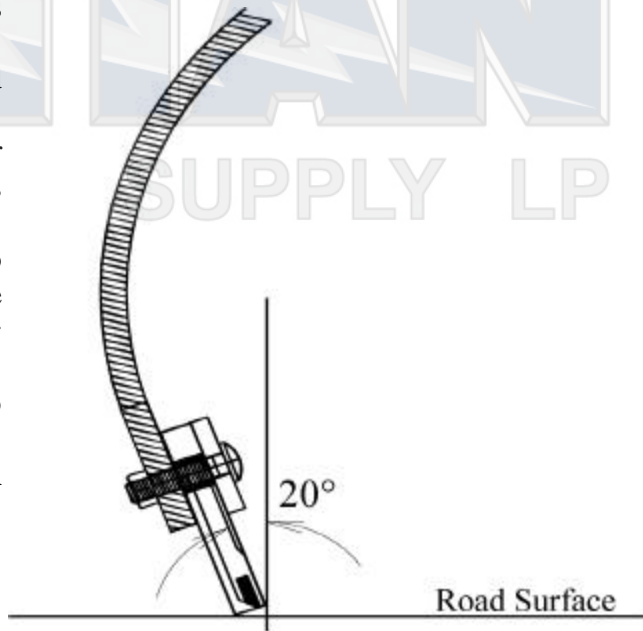

Typical Installation

# JOMA 6000 by Black Cat Blades

## Installation / Operation Instructions

1. The JOMA blade is clearly marked with a “FRONT” stamping. On all **front plows** this front marking must be facing in the direction of travel. This allows for the proper running angle of the carbide inserts to the pavement. Improper mounting on a front plow could result in fracturing carbides leading to premature failure.

2. When mounting the JOMA blades on **underbody plows**, the “FRONT” marking should be facing in to the moldboard.

3. The JOMA blade is supplied with a specially heat treated clamping bar. This bar is placed over the JOMA blade to “clamp” the JOMA to the plow. The clamping bar is supplied with square holes that will accept either a plow bolt or carriage bolt. Grade 8 or better bolts are recommended for installing the JOMA blade.

4. During operation the JOMA blade “seats” itself up into the rubber holder. Do not be alarmed by the rubber being pushed up above the clamping bar, this is normal. As a result of this seating process the JOMA blade actually becomes narrower in it’s first few hours of operation. This can be mistaken for premature wear. Please note, the seating of the JOMA is normal and the blade may appear to have worn when it has actually only compressed. A careful examination of the end of the blade can expose the carbide insert to determine actual wear.

Remove rubber  
Exposing End of  
Segment to in-  
spect carbide  
insert will deter-  
mine wear life  
remaining.



5. When installing the JOMA blade with runner shoes or castors, they should be adjusted approximately 3/4” off the surface when the blades are new. This adjustment places enough weight on the JOMA blade to force the required seating process in the first few hours of operation. Once the JOMA blade has seated, the runners will be contacting the surface and carrying a portion of the weight of the plow, extending blade life.

## JOMA 6000 by Black Cat Blades

### Installation / Operation Instructions (cont.)

6. Operating a plow in a straight-on (dozer) position can result in the blades chattering. Angling the plow should eliminate this. The other cause of excessive chatter or bouncing of the plow is usually caused by a weak trip mechanism as discussed on page 5.

7. If excessive heat is built up on the bottom edge (usually experienced only during dry plowing operations), the rubber may delaminate from the bottom edge of the segments. The thin layer of rubber on the front edge does not affect the performance of the blade and can be removed with a utility knife if unsightly. This thin flap of rubber has also been blamed for excessive snow deflection over the plow and should be removed if this problem is experienced.



This is a typical “well seated” JOMA blade. The rubber has bulged above the clamping bar and the front edge of the segments has been exposed.

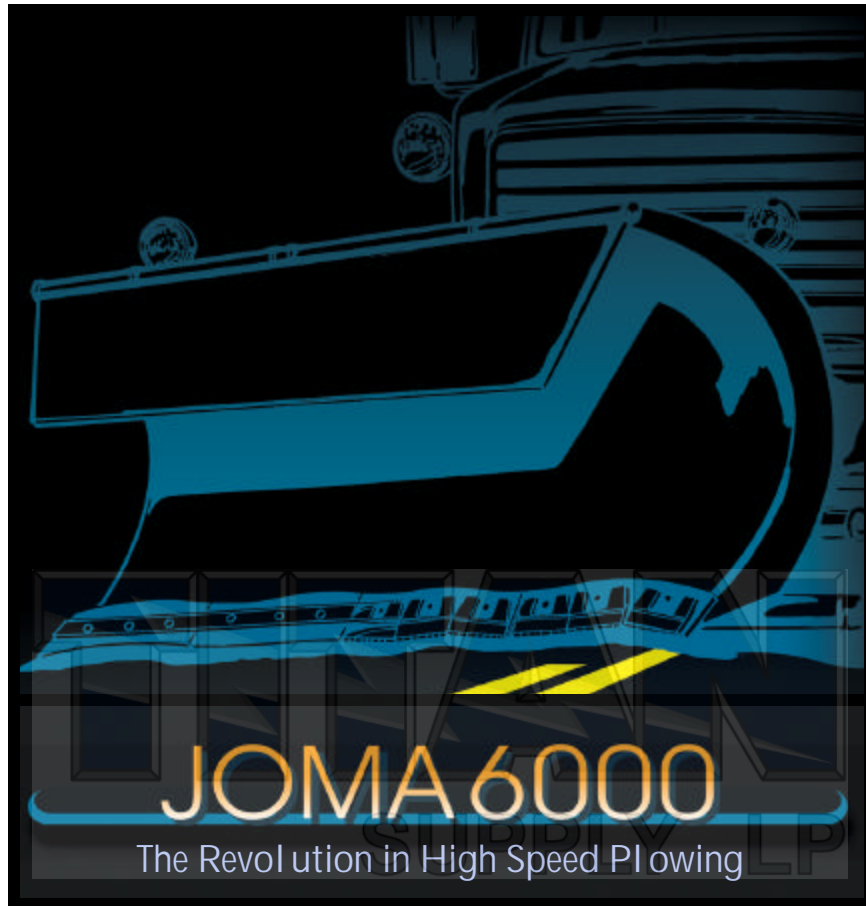

[www.jomablackcat.com](http://www.jomablackcat.com)

**Black Cat Blades Ltd.**  
5604 - 59 Street  
Edmonton, Alberta, Canada  
T6B 3C3

Email: [sales@blackcatblades.com](mailto:sales@blackcatblades.com)  
Toll Free 1-800-661-6666  
Phone: 780-465-6666  
Fax: 780-465-9595



ISO 9002 Certified

The JOMA 6000  
Is Distributed and  
Serviced by: